



The TecCrete Data Center product is based on Global IFS's proven TecCrete access flooring platform. For the last 30 years, it has been the leading choice for architects and developers who require a flooring system with best-in-class features.

ENGINEERED FOR RELIABILITY, SAFETY, AND INSTALLATION EASE

Proprietary Concrete and Steel Composite Design

- Solid rolling load support.
- Steel shear tabs cause the concrete and steel to behave as a single composite material, combining compressive strength and tensile strength for unmatched static and dynamic load performance.
- Industry's only weldless steel pan ensures structural integrity throughout product lifecycle.

Full Panel Thickness

- Superior load-bearing support.
- Solid 1 1/8" or 1 1/2" thick throughout entire panel.
- Full panel thickness rests on understructure, eliminating structural vulnerability at panel edge and corner.

Reduced Airborne Contaminants

- Structural concrete won't flake during installation.
- Limit dust in day-to-day operations.

Ground Path

- Multi-point grounding for dependable static protection and electrical safety.
- Two points of metal-to-metal contact at each corner offer eight points of ground path redundancy on every panel.

Positioning Tab

- Built-in positioning tabs on every stringer eliminates "racking" or skewing of panel grid.

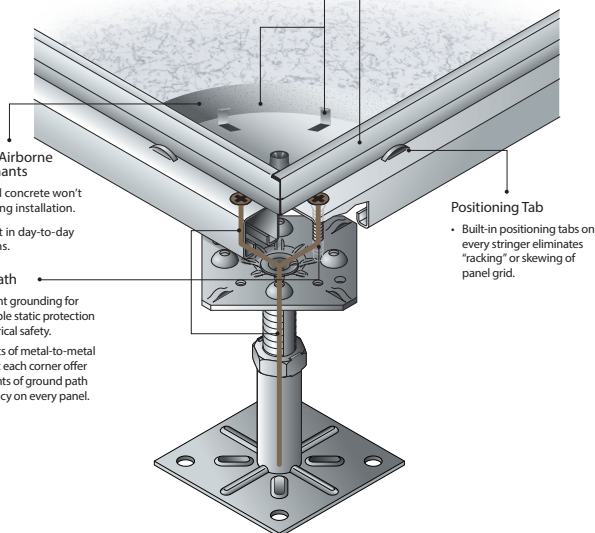

FEATURES

- Industry Leading Warranty- 3 years on the system and 3 years against delamination of HPL or Vinyl
- TecCrete system can be used bare with field applied Electraseal ESD or Electra-guard conductive coatings.
- Optional air seal can be used to reduce cooling loss through the panel seams and provide air containment within the data center plenum creating improved airflow to grates or perforated panels.
- Full range of data center finishes
 - Static Dissipative High Pressure Laminate
 - Conductive High Pressure Laminate
 - Static Dissipative Vinyl
 - Conductive Vinyl

TECCRETE PERFORMANCE

Product			Static Load Rating			Dynamic Load Rating	
System	Panel	Understructure	Concentrated	Uniform	Ultimate	Rolling 10-Pass	Rolling 10,000-Pass
1250	1 1/8" Panel	Cornerlock	1250 lbs	600 lbs	1800 lbs	1300 lbs	900 lbs
1500	1 1/8" Panel	Stringer	1500 lbs	700 lbs	2500 lbs	1500 lbs	1250 lbs
2000	1 1/2" Panel	Stringer	2000 lbs	800 lbs	2800 lbs	1750 lbs	2000 lbs
2500	1 1/2" Panel	HD Stringer	2500 lbs	900 lbs	3100 lbs	2000 lbs	2000 lbs

Standard Duty panel for everyday applications.

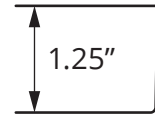

Heavy Duty panel for heavier loads requirements.

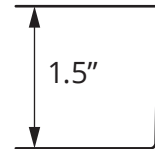

AIRFLOW PANELS



The Global IFS 25% open perforated panel is the best in the industry for data centers, equipment rooms, and some industrial applications when creating a cold aisle to minimize overheating of servers

- Delivers 19% more air volume than competitive equivalent
- Integrated steel grid withstands heavy rolling loads
- Universal design fits any access floor system.

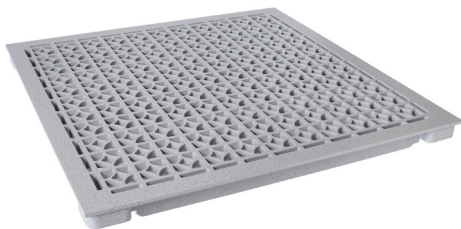

The Global 55% open air grate panel features exceptional air movement and less energy use.

- Delivers twice as much air as the standard 25% open airflow panel, resulting in lower energy costs.
- Constructed from strong, light weight cast aluminum

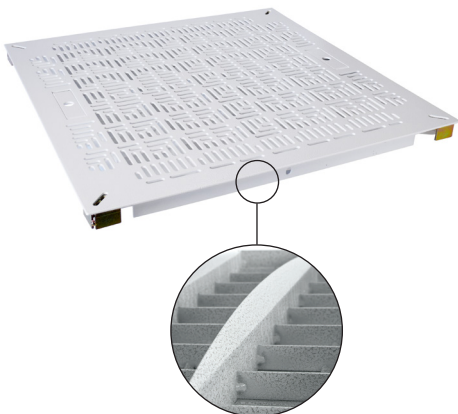

The Triad panel significantly lowers costs by sending cool air directly into data center cabinets, effectively reducing the equipment's temperature—even at the top of the rack. Triad

- Heavy-duty load capacity - concentrated load of 1500 - 5000 lbs.
- Multi-directional fins increase airflow into server units reducing overall cooling costs by up to 40%.
- The higher cooling plume allows cold air to reach the entire height of the rack, resulting in an upper server temperature reduction of 10-20 degrees Fahrenheit.
- Chamfer panel is compatible with all access flooring systems